

NO. 1214
REV.

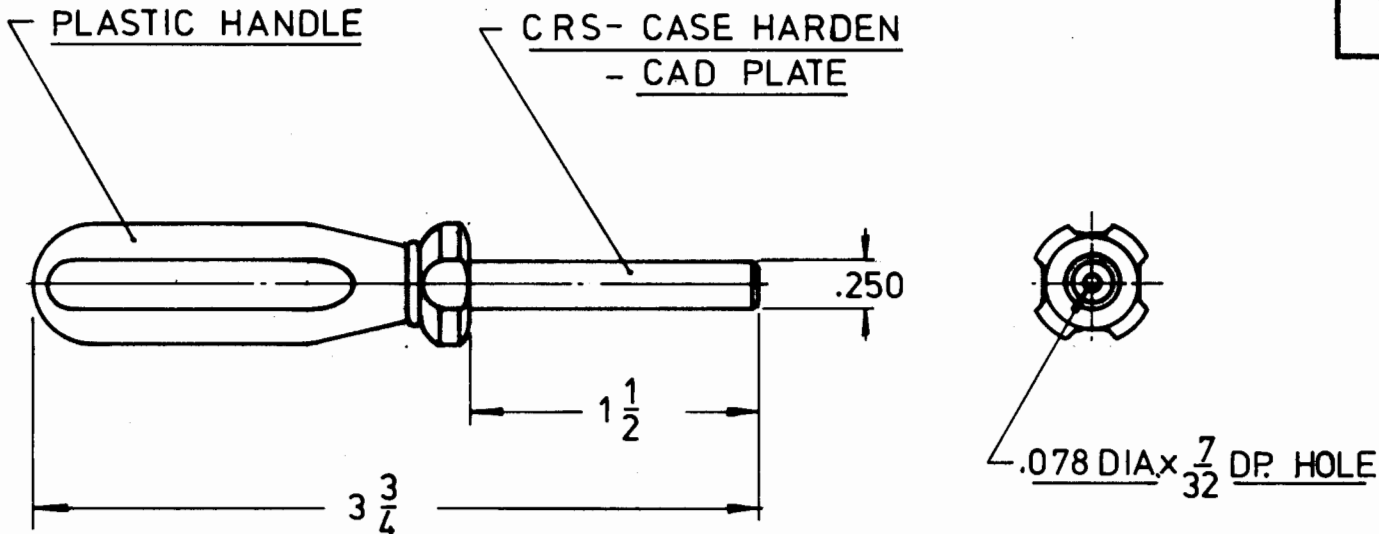

KEYSTONE ELECTRONICS CORP. NEW YORK, N.Y. 10012			
PART NAME		INSERTION TOOL	
MATERIAL		AS NOTED	
FINISH AS NOTED	DRAWN BY	L.N.	DATE 4.14.82
	APPROVED	A.A.	SCALE —
TOLERANCES FRACTIONAL ± .015 DECIMAL ± .005 ANGULAR ± 1/4° UNLESS OTHERWISE NOTED		DWG. NO. 1214	

DATE	REVISION	ISSUE