

THIS DOCUMENT IS THE PROPERTY OF KEYSTONE ELECTRONICS CORP. AND SHALL NOT BE REPRODUCED, DISTRIBUTED OR USED AS A BASIS FOR MANUFACTURE WITHOUT PRIOR WRITTEN PERMISSION FROM KEYSTONE ELECTRONICS CORP.

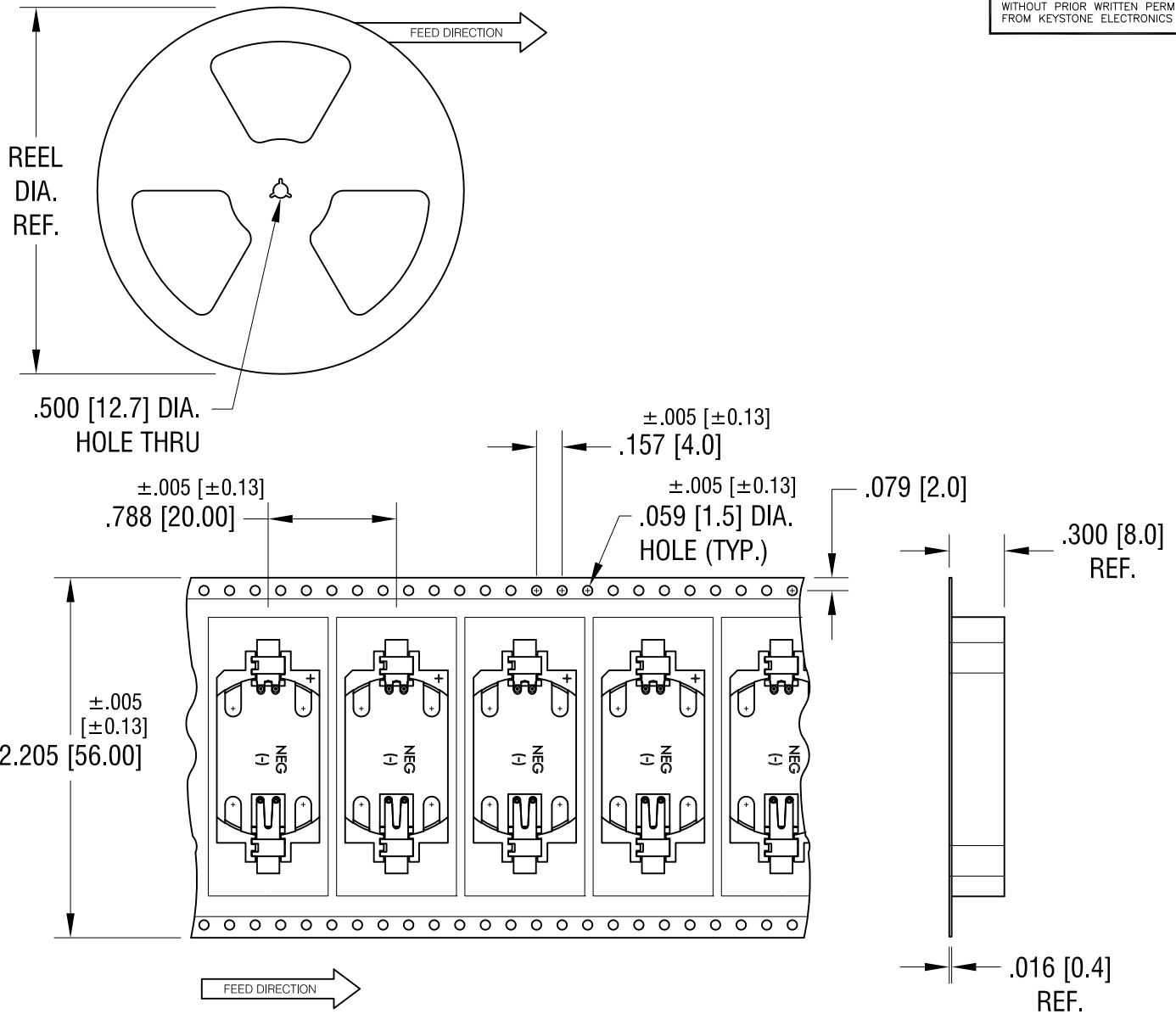

NOTES:

TAPE AND REEL SPECIFICATIONS:

1. TAPE:

MAT'L - ALL CONDUCTIVE POLYSTYRENE CARRIER
ANSI/EIA-481 STANDARD

2. REEL:

13.0 [330.2] DIA. 400 PIECES OF
PART NO. 1052 PER REEL.

5.12.14	PITCH WAS 24mm, WAS 300 PCS CHANGE AS PER ECN 14-051	B
4.02.13	CHANGE AS PER ECN 13-034	A
DATE	DESCRIPTION	REV.

KEYSTONE ELECTRONICS CORP.			
www.keyelco.com • ASTORIA, N.Y. 11105-2017 • Tel (718) 956-8900			
PART NAME 2450 SMT BATTERY HOLDER ON TAPE AND REEL			
MATERIAL AS NOTED			
FINISH AS NOTED		DRN BY NT	DATE 3.11.11
		APP'D LN	SCALE 1X
TOLERANCES DECIMAL ANGULAR	INCH [MM] ± .015 [± 0.38] ± 1°	CODE C	DWG NO. 1052TR
UNLESS OTHERWISE SPECIFIED			