

THIS DOCUMENT IS THE PROPERTY OF
KEYSTONE ELECTRONICS CORP. AND
SHALL NOT BE REPRODUCED, DISTRIBUTED
OR USED AS A BASIS FOR MANUFACTURE
WITHOUT PRIOR WRITTEN PERMISSION
FROM KEYSTONE ELECTRONICS CORP.

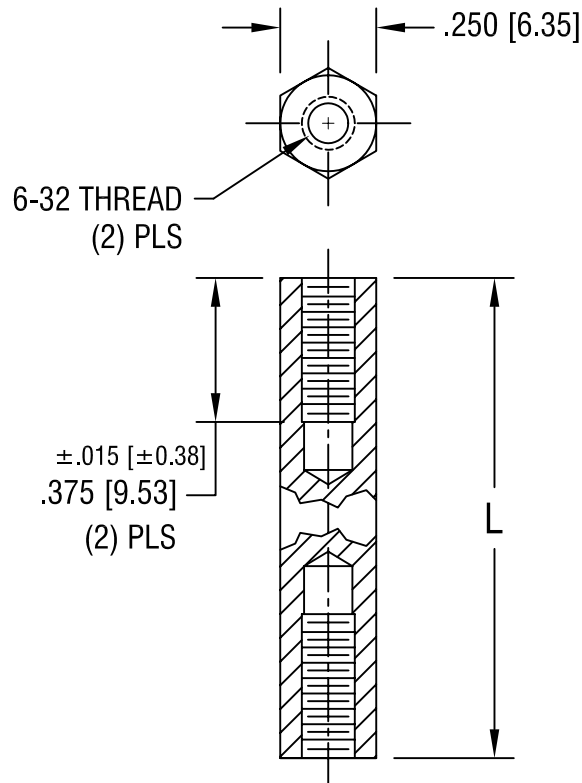

PART NO.	'L' DIM.
1922E	1.500 [38.10]
1922F	2.000 [50.80]

KEYSTONE ELECTRONICS CORP.			
ASTORIA, N.Y. 11105-2017			
PART NAME			
HEX STAINLESS THREADED STANDOFF			
MATERIAL			
STAINLESS STEEL			
FINISH		DRN BY	DATE
-		BOONE	1.11.05
		APPD	SCALE
		LN	2X
TOLERANCES		INCH	[MM]
DECIMAL		± .005	[± 0.15]
ANGULAR		± 1°	
UNLESS OTHERWISE SPECIFIED		CODE	DWG NO.
		C/M	1922E-1922F

DATE	DESCRIPTION	REV.