

DATE	DESCRIPTION	REV.
8.16.12	CHANGE AS PER ECN 12-107	A
10.08.13	CHANGE AS PER ECN 13-090	B

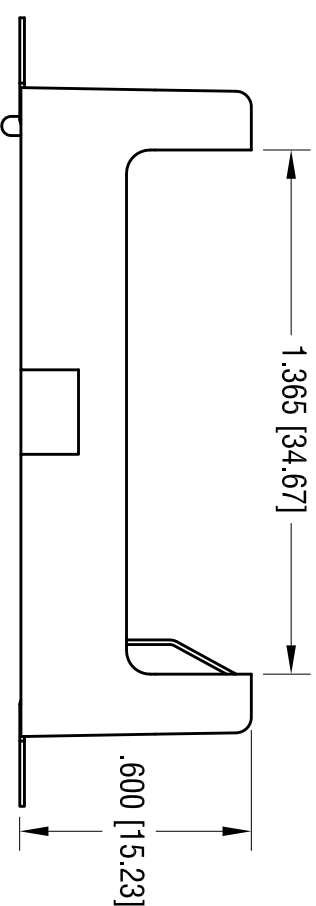

- NOTE:
1. BASE:  
MAT'L: HEAT RESISTANCE NYLON (UL94V-0)  
STANYL 46 OR EQUIVALENT
  2. CONTACT:  
MAT'L: .012 [0.30] THK STAINLESS STEEL  
FINISH: GOLD FLASH, OVER NICKEL PLATE.

ACTUAL SIZE

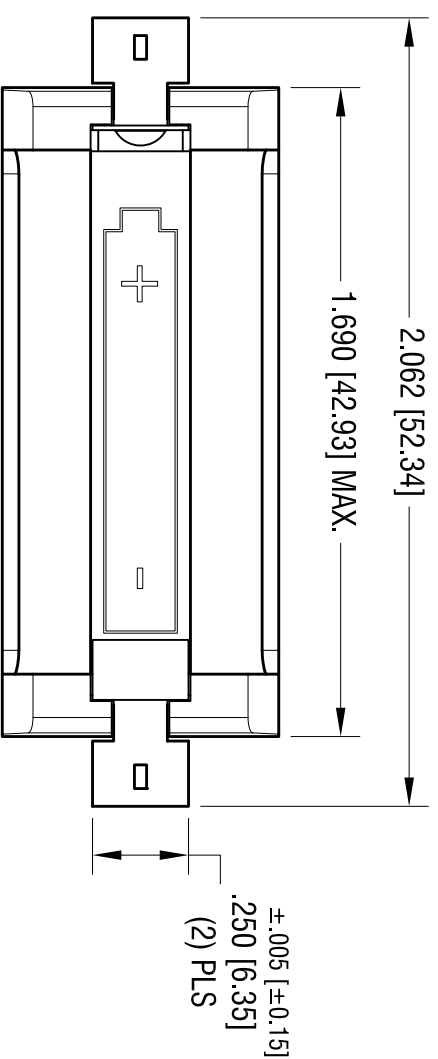
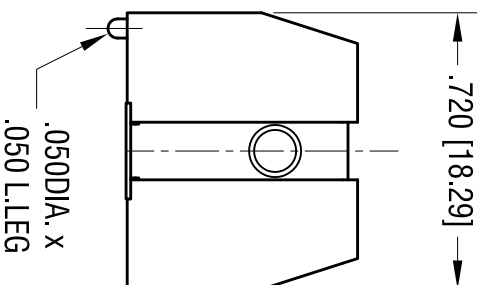
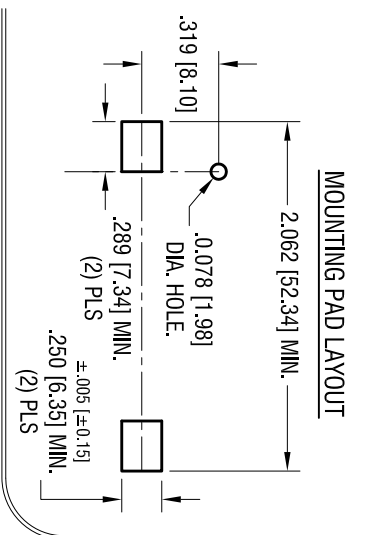
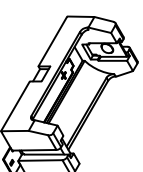

THIS DOCUMENT IS THE PROPERTY OF KEYSTONE ELECTRONICS CORP. AND SHALL NOT BE REPRODUCED, DISTRIBUTED OR USED AS A BASIS FOR MANUFACTURE WITHOUT PRIOR WRITTEN PERMISSION FROM KEYSTONE ELECTRONICS CORP.

<b>KEYSTONE ELECTRONICS CORP.</b>			
www.keystec.com • ASTORIA, N.Y. 11105-2017 • Tel (718) 956-8900			
PART NAME SM BATTERY HOLDER, CR123A			
MATERIAL AS NOTED			
FINISH AS NOTED			
TOLERANCES	INCH	[MM]	CODE
DECIMAL	± .010	[± ]	C
ANGULAR	± 1°	[± ]	
UNLESS OTHERWISE SPECIFIED			
DRN BY	NT	DATE	1.19.12
APP'D	LN	SCALE	2X
DWG NO.		1050	