

**MOUNTING PAD LAYOUT**

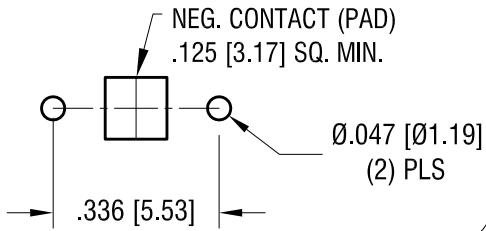

THIS DOCUMENT IS THE PROPERTY OF KEYSTONE ELECTRONICS CORP. AND SHALL NOT BE REPRODUCED, DISTRIBUTED OR USED AS A BASIS FOR MANUFACTURE WITHOUT PRIOR WRITTEN PERMISSION FROM KEYSTONE ELECTRONICS CORP.

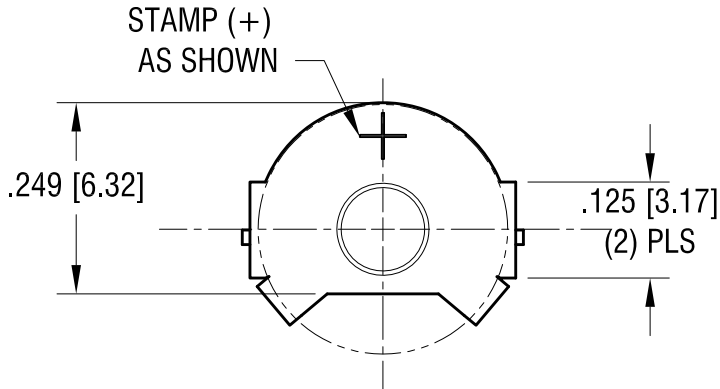
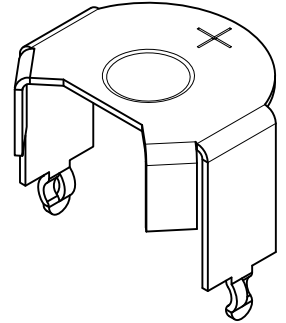

**SECTION A-A**

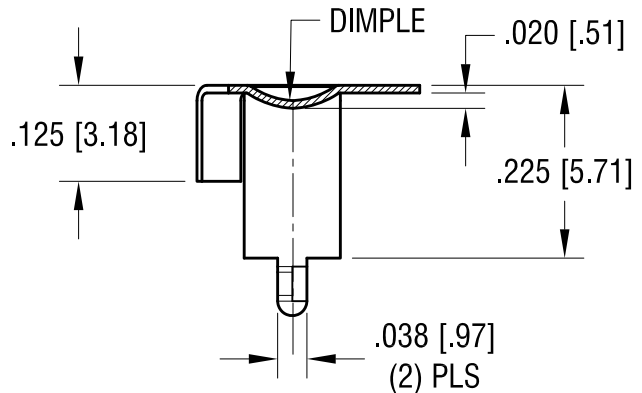
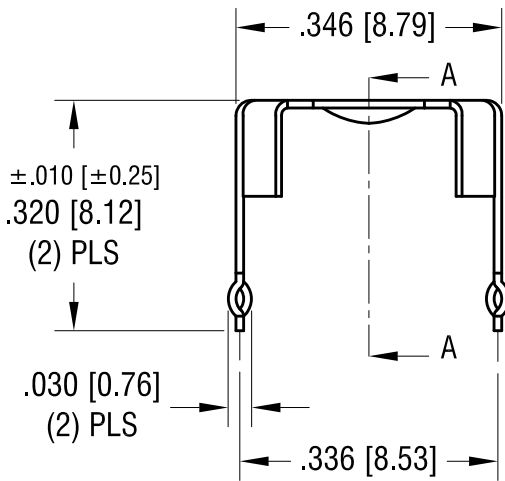

7.18.12	CHANGE AS PER ECN 12-086	A
DATE	DESCRIPTION	REV.

<b>KEYSTONE ELECTRONICS CORP.</b>		
www.keyelco.com • ASTORIA, N.Y. 11105-2017 • Tel (718) 956-8900		
PART NAME		
THM HEARING AID BATTERY RETAINER (SIZE 13)		
MATERIAL		
.010 [0.25] TH'K PHOSPHOR BRONZE		
FINISH	DRN BY	DATE
TIN NICKEL PLATE	NT	5.04.11
	APP'D	SCALE
	LN	4X
TOLERANCES	INCH	[MM]
DECIMAL	± .005	[± 0.13]
ANGULAR	± 1°	
UNLESS OTHERWISE SPECIFIED		
CODE	DWG NO.	
C	<b>2989</b>	