

MOUNTING PAD LAYOUT REQUIRED FOR (2) 'AAAA' CLIPS

THIS DOCUMENT IS THE PROPERTY OF KEYSTONE ELECTRONICS CORP. AND SHALL NOT BE REPRODUCED, DISTRIBUTED OR USED AS A BASIS FOR MANUFACTURE WITHOUT PRIOR WRITTEN PERMISSION FROM KEYSTONE ELECTRONICS CORP.

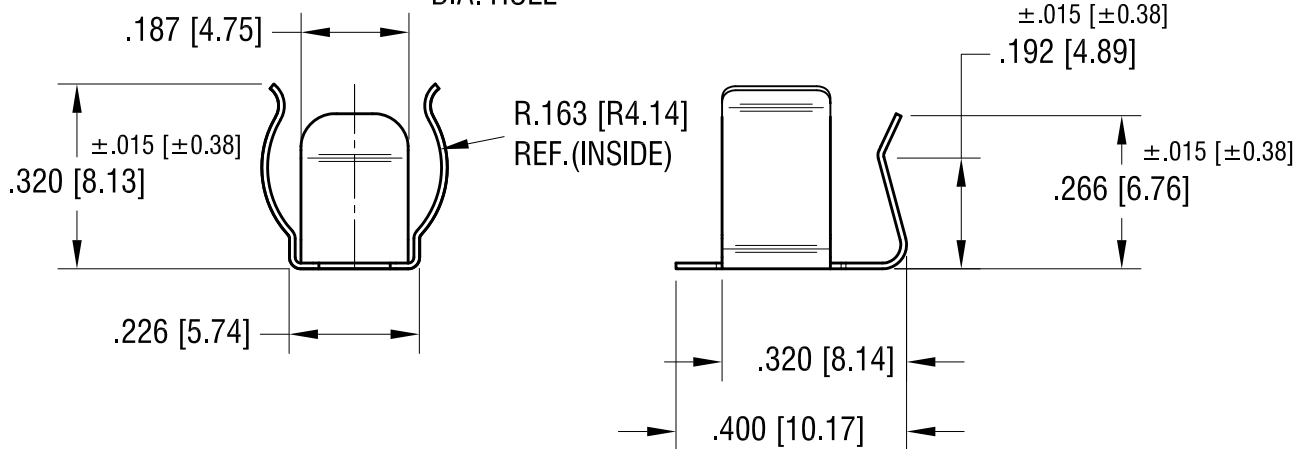
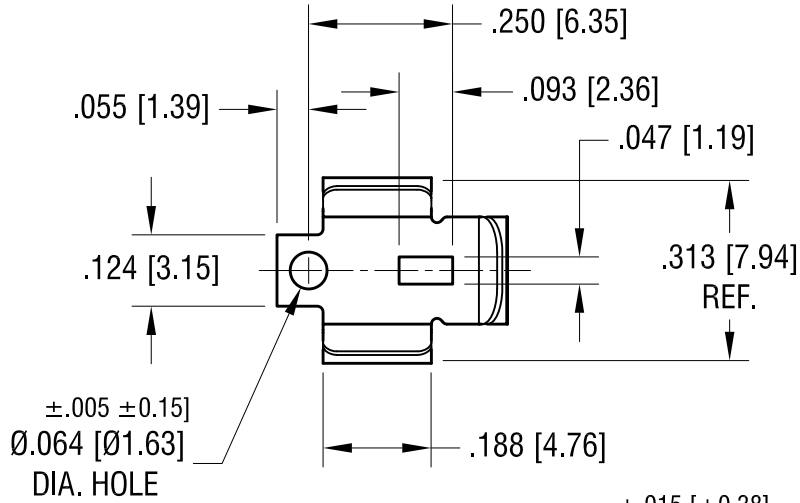
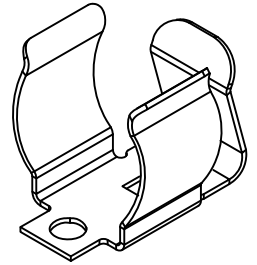
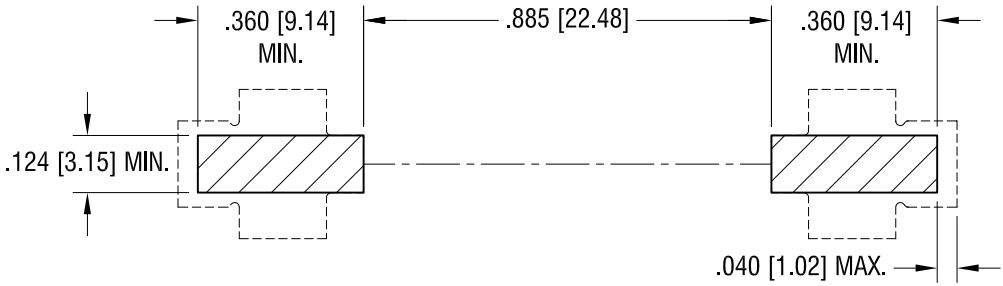

NOTE:

1. HEAT TREAT TO SPRING TEMPER

KEYSTONE ELECTRONICS CORP.

www.keyelco.com • ASTORIA, N.Y. 11105-2017 • Tel (718) 956-8900

PART NAME		'AAAA' SMT BATTERY CLIP	
MATERIAL		.010 [0.25] TH'K ANNEALED SPRING STEEL	
FINISH		DRN BY	DATE
TIN NICKEL PLATE		BOONE	9.5.03
		APP'D	SCALE
		LN	3X
TOLERANCES	INCH [MM]	CODE	DWG NO.
DECIMAL	± .010 [± 0.25]	C	50
ANGULAR	± 1°		
UNLESS OTHERWISE SPECIFIED			

10.1.09	CHANGE AS PER ECN 09-141	D
6.04.09	CHANGE AS PER ECN 09-049	C
10.30.07	CHANGE AS PER ECN 07-072	B
11.12.04	CHANGE AS PER ECN 04-138	A
DATE	DESCRIPTION	REV.