

DATE	DESCRIPTION	REV.
10.08.13	CHANGE AS PER ECN 13-091	A

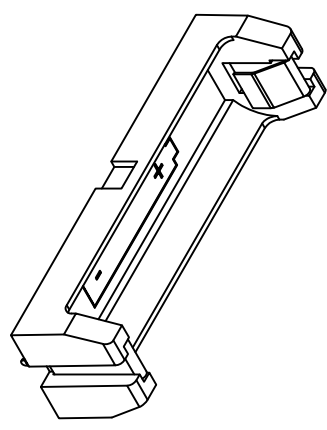
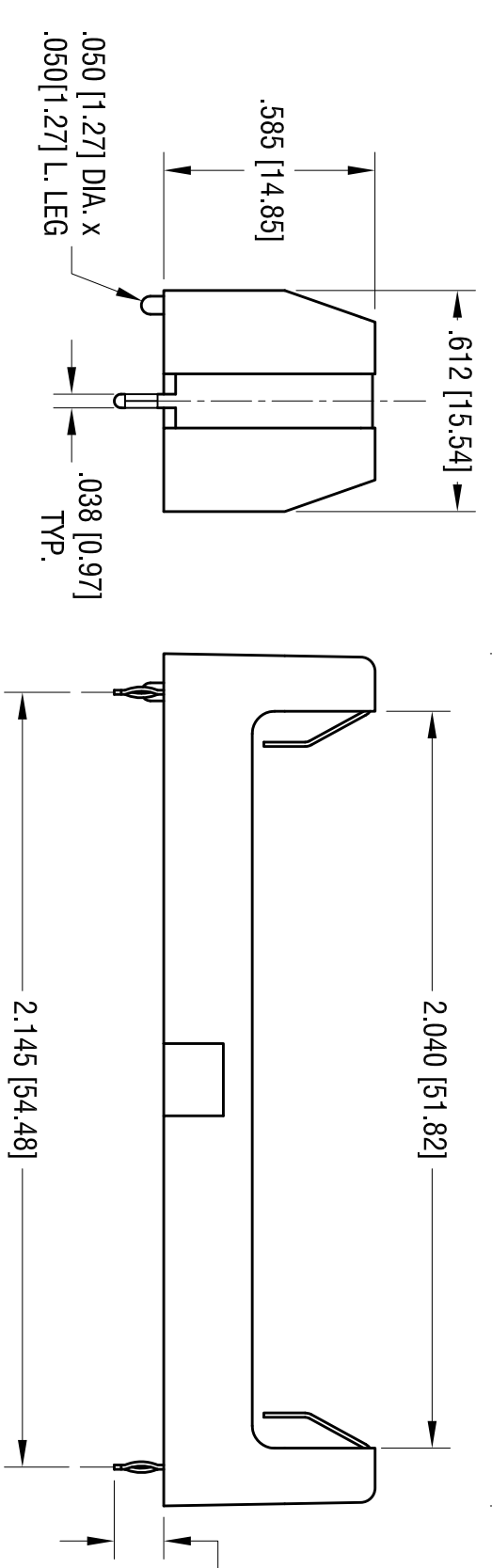
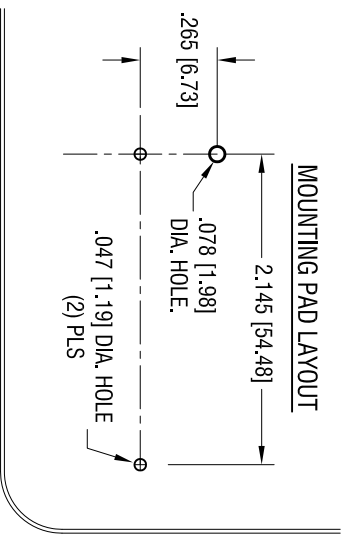

- NOTE:
1. BASE:
MATE'L: HEAT RESISTANCE NYLON
STANLYL 46 OR EQUIVALENT
 2. CONTACT:
MATE'L: .012 [0.30] THK STAINLESS STEEL
FINISH: TIN NICKEL PLATE

THIS DOCUMENT IS THE PROPERTY OF KEYSTONE ELECTRONICS CORP. AND SHALL NOT BE REPRODUCED, DISTRIBUTED OR USED AS A BASIS FOR MANUFACTURE WITHOUT PRIOR WRITTEN PERMISSION FROM KEYSTONE ELECTRONICS CORP.

KEYSTONE ELECTRONICS CORP.			
www.keystec.com • ASTORIA, N.Y. 11105-2017 • Tel (718) 956-8900			
PART NAME		THM BATTERY HOLDER, AA	
MATERIAL		AS NOTED	
FINISH		AS NOTED	
TOLERANCES	INCH	[MM]	CODE
DECIMAL	± .010	[± 0.25]	C
ANGULAR	± 1°		
UNLESS OTHERWISE SPECIFIED			
DRN BY	NT	DATE	3.11.10
APP'D	LN	SCALE	2X
DWG NO.		1015	